

## Appearance and size

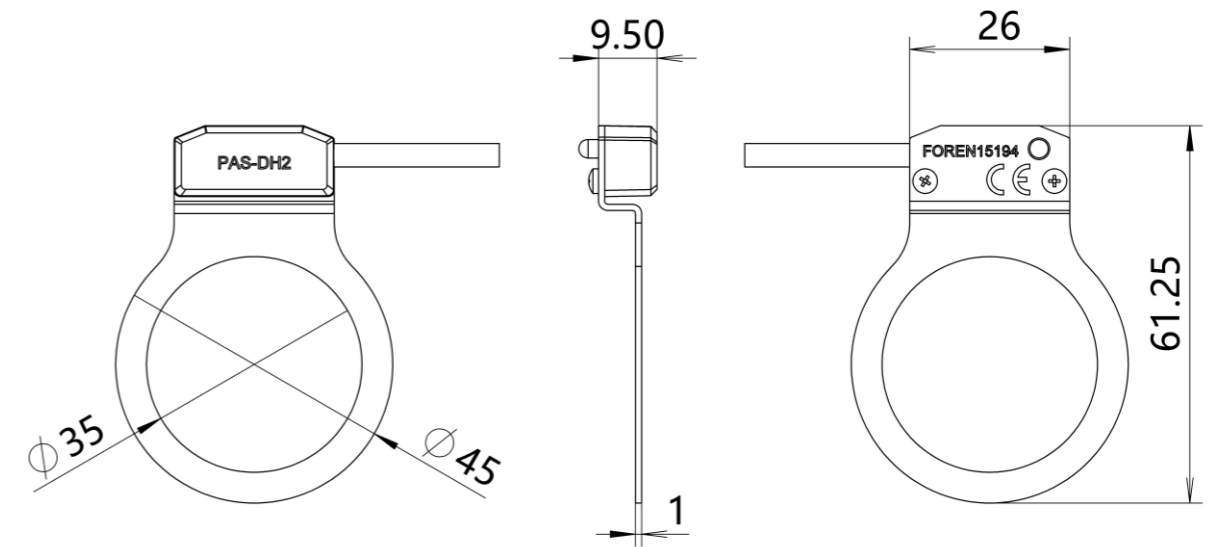

## Installation Instructions

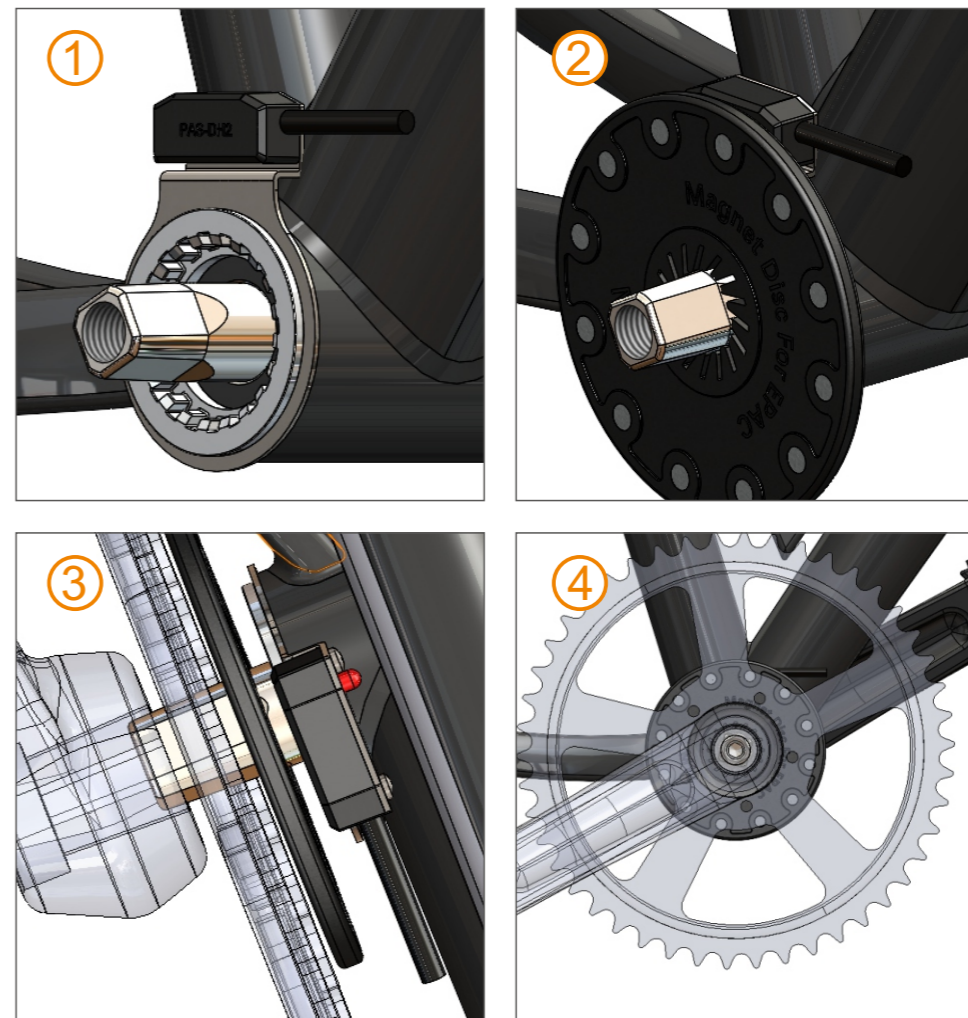

## Description

PAS-D12 is a pedal assist sensor for bike, it was combined with 2 parts , one is a disc with 12 magnet ,other is a sensor.

Automatic moving direction detect , so this sensor can check the moving direction while pedaling , sending out signal when forward and stop sending when backwards.

There have a indicator on sensor , it can help user to check the sensor is working or not . Or check the installation is correct or not .

## Specification

• Model	: PAS-D12
• Power	: 5V/2mA
• Signal	: Forward-12Pules Per Circle Reverse -None
• Indicator	: Red Light
• Material	: PC
• Wegiht	:7.8g
• Axel Size	:15-15.8mm